

NEW Mixing Valve ADA Covers



Make Sure You're ADA Compliant!

Exposed mixed water supply must be insulated.

PVC Antifungal, Antimicrobial

ASTM E84 Fire & Smoke Tested

Hook & Loop Fastened

Super Fast Installation

ADA
"Water supply and drainpipes under lavatories and sinks shall be insulated"
(ADA, ANSI 117)



**3021-MIX60
Mixing Valve
Supply Cover**

Valve Cover
with
MIX60 Valve



**3200W Thermostatic
Mixing Valve Cover
Universal Fit**

Valve Cover with Thermostatic Mix Valve

Optimum Flexibility for New Plumbing Code Required Tempering Valve Installations

Quality ADA Specialty Products from

Proudly
Made In
America



PLUMBEREX
SPECIALTY PRODUCTS INC.
Engineering Smart Solutions

P.O. Box 1684 | Palm Springs, CA 92263
(760) 343-7363 | www.plumberex.com

PLUMBEREX

SPECIALTY PRODUCTS INC

ADA Specialty Products



ADA
Compliant for Americans
with Disabilities Act
and IAPMO Listed

SUBMITTAL SHEET

PROJECT	
DWG #	
ITEM #	

#3021 Mix 60 Valve & Supply Cover

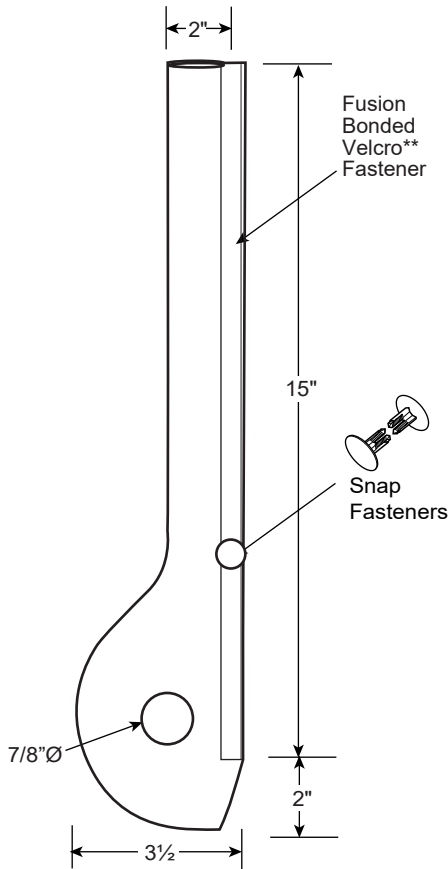

Detail: Mix Valve and Water Supply with Cover

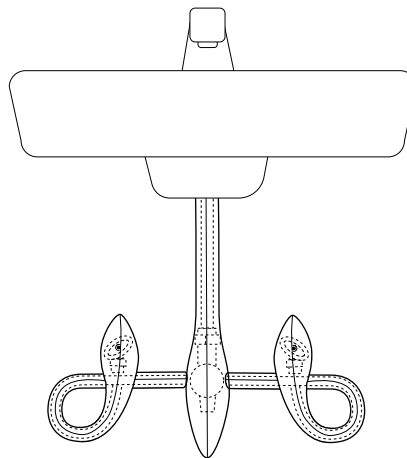
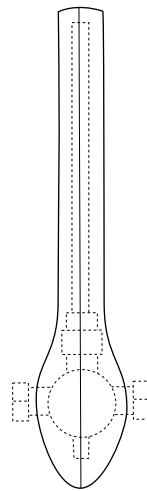

Optimum Flexibility for
Plumbing Code Required
Mixing Valve Installations

SUGGESTED SPECIFICATION

Insulate per ADA 4.19.4 and or ANSI A117.1 all exposed water, valve supplies and drain piping. Protectors shall conform to ASTM C1822 Type I. Protectors will consist of one-piece cover with a smooth, soft texture, anti-fungal, anti-microbial, closed cell vinyl with heat welded construction. Insulation shall conform to International Building Code (IBC) with testing standard of ASTM E84-07 Class A Material (25 Flame/450 Smoke) criteria. Protectors shall consist of a dual fastening system of Velcro* Fastening Strips and tamper resistant self-locking snap fasteners. Protectors must be secured by Heavy-Duty, Self-Locking, Snap Fasteners for permanent safe fit option to deter theft and/or injury.

**Manufacturer: Plumberex
Specialty Products Inc.
Model #3201 Mix 60**

brand and shall consist of all the above listed components and features.

*Velcro is a registered trademark of Velcro USA Inc.

PRODUCT DETAIL:

For thermostatic and mixing valves, exposed piping and supply stop protectors requiring compliance with ADA 4.19.4 covers attach by a dual fastening system of a 3/4" Velcro strip and tamper resistant, self-locking snap fasteners. Surfaces are easy to clean non-absorbent vinyl with U/V inhibited, antifungal/anti microbial agents.

PART NUMBER BY PRODUCT

*Note: All model colors are white

MODEL # 3201 Mix 60
Mixing Valve & Supply Cover

Available color options:

White	Gray	Almond	Black

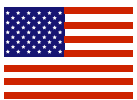

MADE IN USA

PLUMBEREX
SPECIALTY PRODUCTS INC.

P.O. Box 1684 Palm Springs, CA 92263 (760) 343-7363 1-800-475-8629 FAX (760)343-7366
Plumberex Specialty Products, Inc. Reserves the right to make changes or improvements at any time without notice.

© 2008 Plumberex Specialty Products, Inc.